

# ALP TEX

## Probes For Fine Pitch Connections

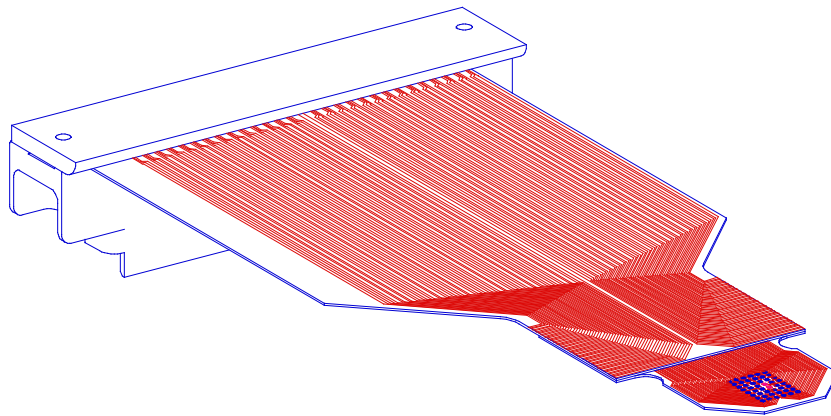

microBGA FlexProbes  
0,75mm (.0295") Pitch

# microBGA FlexProbes 0,75mm (.0295") Pitch

## Data/Application Sheets

ALPTEX Part Number	Description
923741	Standard Pinout, "Hermit" Connector, Direct Solder Type, 40/48 Lead
923742	Standard Pinout, Socket Connector, Direct Solder Type, 40/48/56 Lead

.pdf files are also available for the following:

- 0,5mm (.0197") Pitch TSOP FlexProbes...TSOP\_FP.pdf
- 0,8mm (.0315") Pitch SSOP FlexProbes...SSOP\_FP.pdf
- 1,27mm (.050") Pitch PSOP FlexProbes...PSOP\_FP.pdf
- 1,27mm (.050") Pitch PLCC FlexProbes...PLCC\_FP.pdf
- 1,00mm (.0394") Pitch BGA FlexProbes...BGA\_FP.pdf
- FlexProbe Extenders...EXTENDFP.pdf

# 0,75mm microBGA FlexProbe (Direct Solder)

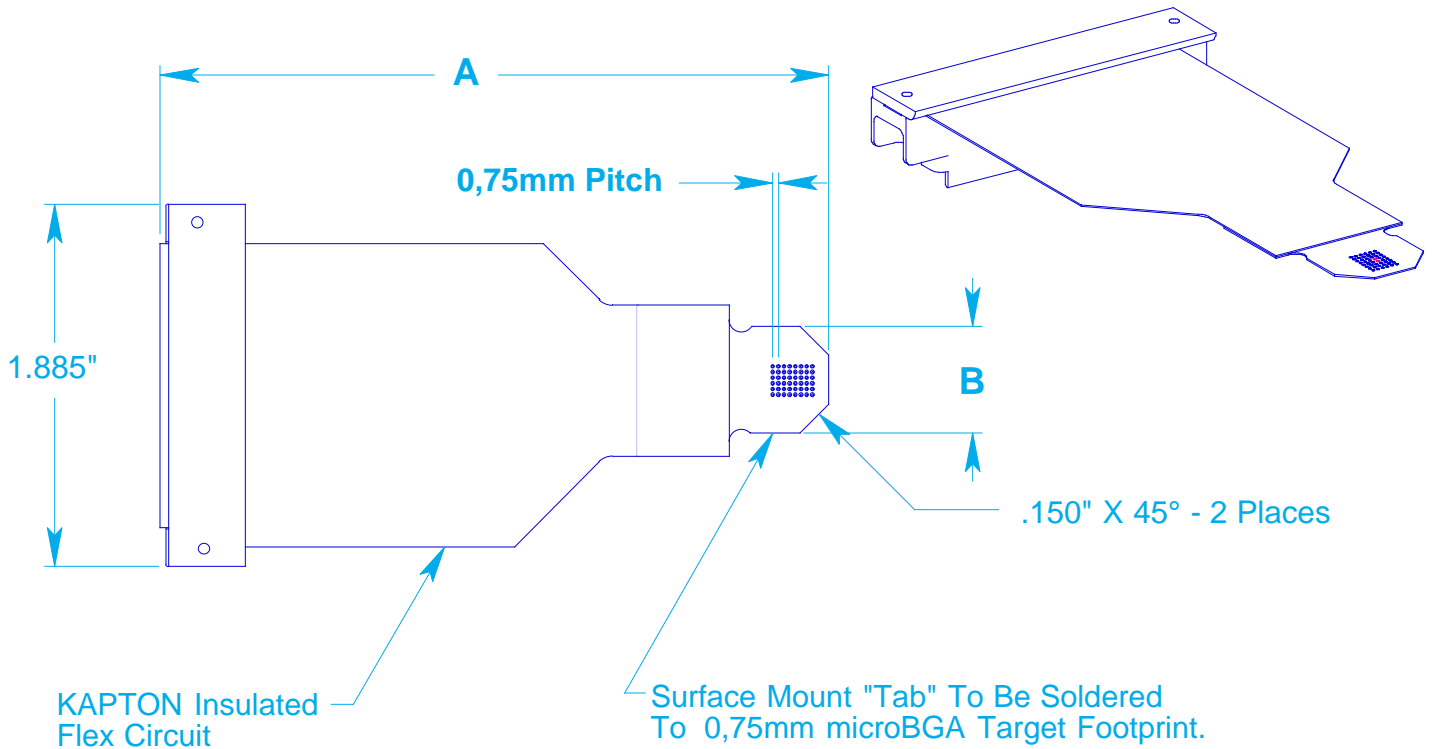

PACKAGE	# LEADS	DIMENSION		ALPTEx
		A	B	PART NUMBER
0,75mm microBGA	40	3.441	.468	923741-40
	48	3.482	.557	923741-48

## FEATURES:

- THE MOST FLEXIBLE "TARGET" INTERCONNECT AVAILABLE...MINIMIZES PHYSICAL STRAIN ON THE TARGET PADS.
- A UNIQUE SOLUTION FOR CONNECTING DIRECTLY TO YOUR P. C. BOARD.
- REFLOW SOLDERS TO STANDARD 0,75mm microBGA PAD PATTERN.
- ELIMINATES NEED TO ALTER P. C. BOARD BETWEEN DEVELOPMENT AND PRODUCTION PHASES.
- COMPACT LENGTH VIRTUALLY ELIMINATES CROSSTALK / EMI PROBLEMS.
- MERITEC HERMAPHRODITIC CONNECTOR PROVIDES A DEPENDABLE AND COMPACT INTERFACE FOR YOUR TEST / EMULATION CIRCUITRY.
- MADE ENTIRELY IN THE U.S.A.
- FLEXPROBES FOR EMULATING OTHER POPULAR COMPONENT PACKAGES ARE ALSO AVAILABLE...CONSULT FACTORY.

**ALPTEx** Incorporated  
P.O. Box 476  
Orwell, Ohio 44076  
(440)437-5570 • (440)437-5571 FAX  
[www.alptex.com](http://www.alptex.com)

ALL STATEMENTS, SPECIFICATIONS AND TECHNICAL INFORMATION ON THIS DATA SHEET ARE SUBJECT TO CHANGE AT ANY TIME WITHOUT NOTICE.

# 0,75mm microBGA FlexProbe

## Application Data ALPTEX Part Number 923741-XX (Direct Solder)

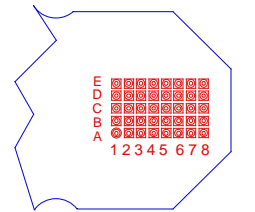
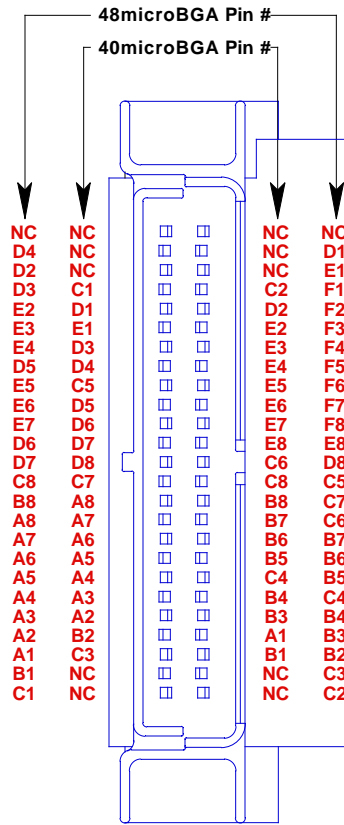

(40 microBGA)

### FlexProbe Pinout As Viewed From Bottom (Interface Connector - Near Side)



(48 microBGA)

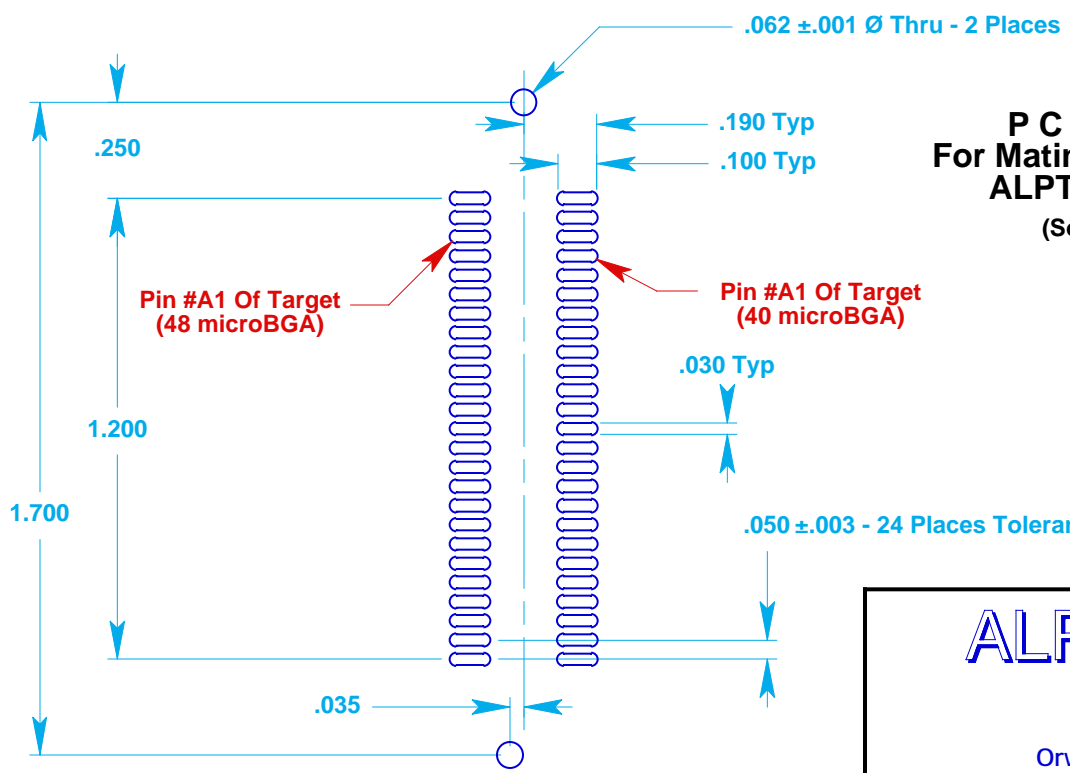

### P C Board Pad Pattern For Mating MERITEC Connector ALPTEX Part #923718-50 (Solder Pads - Near Side)

**ALP  
TEX** Incorporated  
P.O. Box 476  
Orwell, Ohio 44076  
(440)437-5570 • (440)437-5571 FAX  
[www.alptex.com](http://www.alptex.com)

CONTENTS

PRODUCT INFO

APP NOTES

ALL STATEMENTS, SPECIFICATIONS AND TECHNICAL INFORMATION ON THIS DATA SHEET ARE SUBJECT TO CHANGE AT ANY TIME WITHOUT NOTICE.

# 0,75mm microBGA FlexProbe

## Application Note

### ALPTEX Part Number 923741-XX & 923742-XX (Direct Solder)

ALPTEX FLEXPROBES ARE PRODUCED USING THE HIGHEST QUALITY MATERIALS AND MANUFACTURING TECHNIQUES. AS WITH ANY OTHER PRECISION INSTRUMENT, IT SHOULD BE HANDLED WITH CARE.

#### SUGGESTED SHOP SUPPLIES:

63/37 or 60/40 Solder.... .015" Dia.  
Liquid Flux.... \*Superior #334 No-Clean  
Flux Remover.... \*Chemtronics Flux-Off 2000  
Tape.... (Masking, \*Scotch, etc.)

#### SUGGESTED SHOP EQUIPMENT:

Microscope  
\*Weller Solder Station #MT1500 @ 650°  
\*Weller Solder Tip #302 (or Equivalent)

1. Under microscope, Pre-tin solder pads of mBGA target to create consistent solder "bumps".
2. Cut alignment template from template strip.
3. Remove protective backing from adhesive and apply template over mBGA target, aligning template marks to solder pads as illustrated.

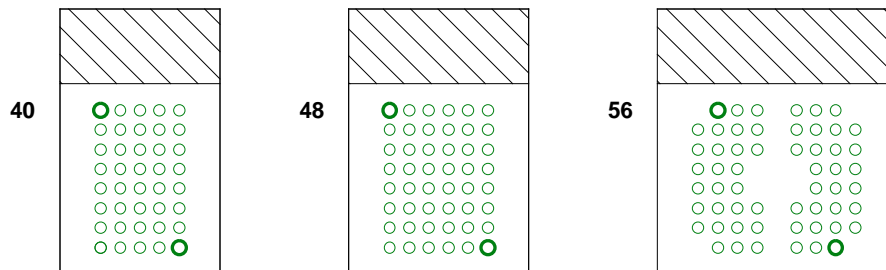

4. Apply 2 pieces of tape (1/4"x1/4" sq.) to the sides of microBGA FlexProbe.
5. Slide FlexProbe under template and align correct solder pads to marks on template. Press down tape to hold in place.

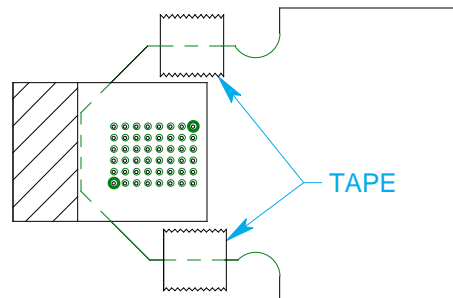

6. Remove alignment template.
7. Apply liquid flux as required.
8. Reflow solder FlexProbe to target by touching the solder tip to each pad on the FlexProbe. Start at the center of the pattern and work to the edges in a spiral manner.
9. Clean solder joints with flux remover.
10. Carefully plug connector end of FlexProbe into adaptor board or extender.

BY OBSERVING THESE INSTRUCTIONS YOU CAN BE ASSURED OF GETTING THE LONGEST PRODUCT LIFE POSSIBLE. DISREGARDING THESE INSTRUCTIONS MAY RESULT IN FAILURE OF THE FLEX CIRCUIT AND WOULD VOID THE WARRANTY OF YOUR FLEXPROBE.

**ALP  
TEX** Incorporated  
P.O. Box 476  
Orwell, Ohio 44076  
(440)437-5570 • (440)437-5571 FAX  
[www.alptex.com](http://www.alptex.com)

# 0,75mm microBGA FlexProbe (Direct Solder)

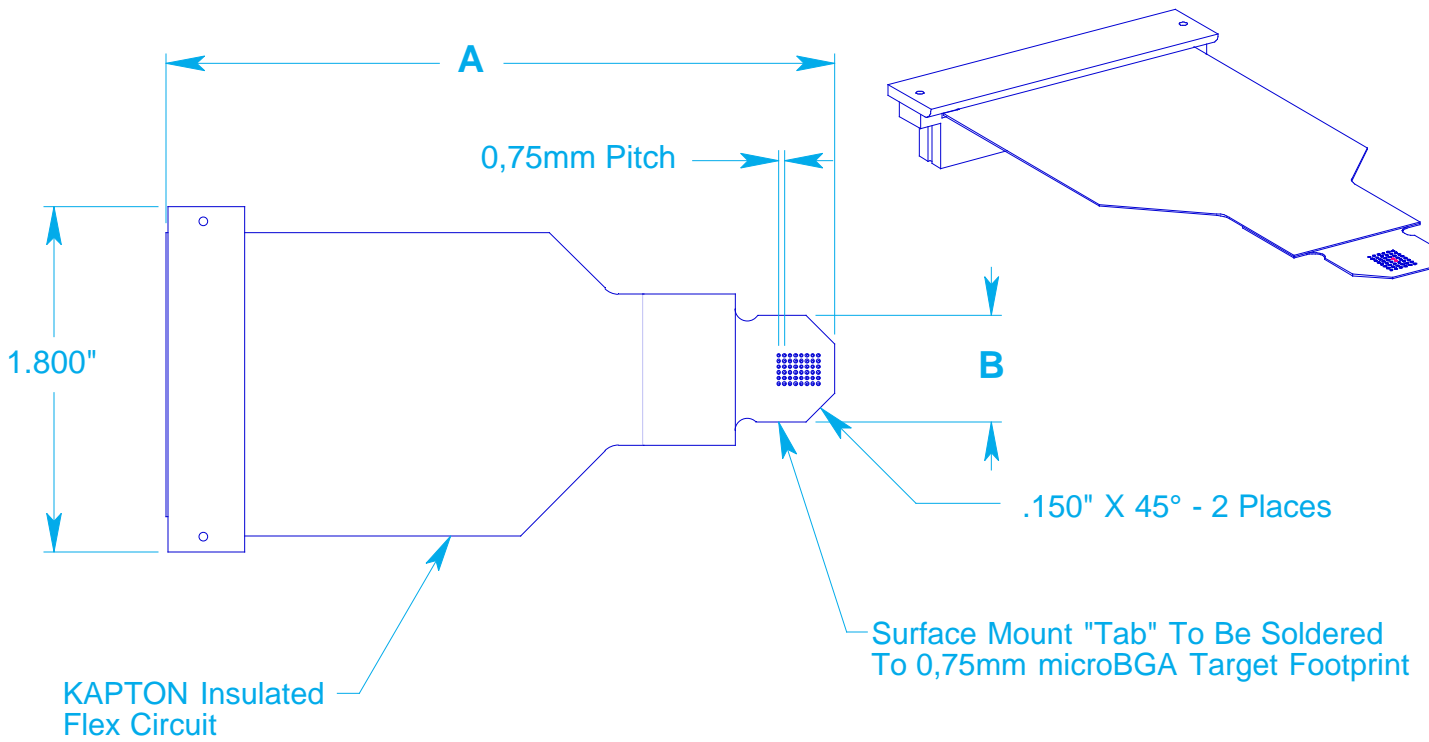

PACKAGE	# LEADS	DIMENSION		ALPTEX PART NUMBER
		A	B	
0,75mm microBGA	40	3.441	.468	923742-40
	48	3.482	.557	923742-48
	56	3.524	.633	923742-56

## FEATURES:

- THE MOST FLEXIBLE "TARGET" INTERCONNECT AVAILABLE...MINIMIZES PHYSICAL STRAIN ON THE TARGET PADS.
- A UNIQUE SOLUTION FOR CONNECTING DIRECTLY TO YOUR P. C. BOARD.
- REFLOW SOLDERS TO STANDARD 0,75mm microBGA PAD PATTERN.
- ELIMINATES NEED TO ALTER P. C. BOARD BETWEEN DEVELOPMENT AND PRODUCTION PHASES.
- COMPACT LENGTH VIRTUALLY ELIMINATES CROSSTALK / EMI PROBLEMS.
- MADE ENTIRELY IN THE U.S.A.
- FLEXPROBES FOR EMULATING OTHER POPULAR COMPONENT PACKAGES ARE ALSO AVAILABLE...CONSULT FACTORY.

**ALP**  
**TEX** Incorporated  
 P.O. Box 476  
 Orwell, Ohio 44076  
 (440)437-5570 • (440)437-5571 FAX  
[www.alptex.com](http://www.alptex.com)

ALL STATEMENTS, SPECIFICATIONS AND TECHNICAL INFORMATION ON THIS DATA SHEET ARE SUBJECT TO CHANGE AT ANY TIME WITHOUT NOTICE.

CONTENTS

APP DATA

APP NOTES



# 0,75mm microBGA FlexProbe

## Application Note

### ALPTEx Part Number 923741-XX & 923742-XX (Direct Solder)

ALPTEx FLEXPROBES ARE PRODUCED USING THE HIGHEST QUALITY MATERIALS AND MANUFACTURING TECHNIQUES. AS WITH ANY OTHER PRECISION INSTRUMENT, IT SHOULD BE HANDLED WITH CARE.

#### SUGGESTED SHOP SUPPLIES:

63/37 or 60/40 Solder.... .015" Dia.  
Liquid Flux.... \*Superior #334 No-Clean  
Flux Remover.... \*Chemtronics Flux-Off 2000  
Tape.... (Masking, \*Scotch, etc.)

#### SUGGESTED SHOP EQUIPMENT:

Microscope  
\*Weller Solder Station #MT1500 @ 650°  
\*Weller Solder Tip #302 (or Equivalent)

1. Under microscope, Pre-tin solder pads of mBGA target to create consistent solder "bumps".
2. Cut alignment template from template strip.
3. Remove protective backing from adhesive and apply template over mBGA target, aligning template marks to solder pads as illustrated.

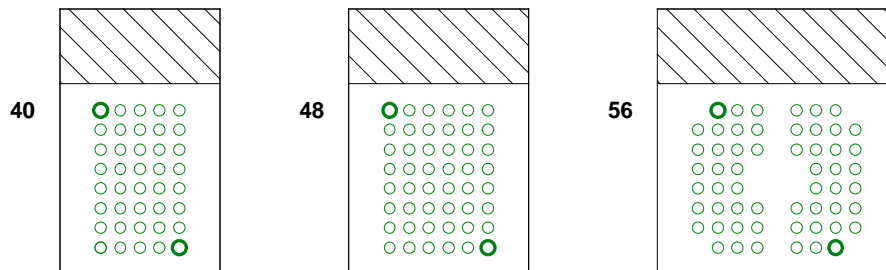

4. Apply 2 pieces of tape (1/4"x1/4" sq.) to the sides of microBGA FlexProbe.
5. Slide FlexProbe under template and align correct solder pads to marks on template. Press down tape to hold in place.

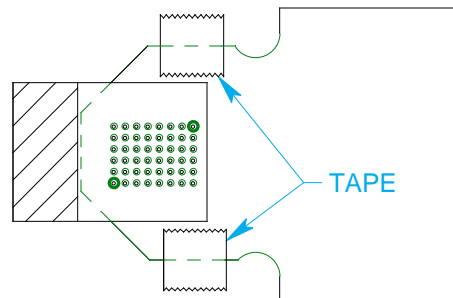

6. Remove alignment template.
7. Apply liquid flux as required.
8. Reflow solder FlexProbe to target by touching the solder tip to each pad on the FlexProbe. Start at the center of the pattern and work to the edges in a spiral manner.
9. Clean solder joints with flux remover.
10. Carefully plug connector end of FlexProbe into adaptor board or extender.

BY OBSERVING THESE INSTRUCTIONS YOU CAN BE ASSURED OF GETTING THE LONGEST PRODUCT LIFE POSSIBLE. DISREGARDING THESE INSTRUCTIONS MAY RESULT IN FAILURE OF THE FLEX CIRCUIT AND WOULD VOID THE WARRANTY OF YOUR FLEXPROBE.

**ALPTEx** Incorporated  
P.O. Box 476  
Orwell, Ohio 44076  
(440)437-5570 • (440)437-5571 FAX  
[www.alptex.com](http://www.alptex.com)